

# Classic

METAL DETECTOR

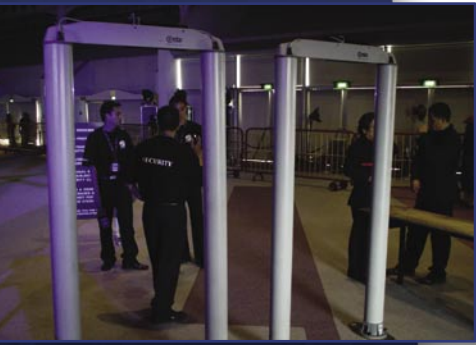

- **High Security Detection**
- **Leading Edge Technology**
- **Easy to Install and Use**
- **Suitable for Portable Applications**
- **No Maintenance Required**
- **Affordable Pricing**

**CEIA**, the world leading manufacturer of Metal Detectors, presents the **Classic**. This Walk-Through Metal Detector is engineered and designed to meet the **specific security needs of public facilities** such as: schools, hotels, amusement parks and city halls. The **Classic** provides the required security with a high level of operating efficiency. The leading edge technology features a **high flow rate** of people through the gate with minimal alarms. Personal items such as coins, keys, belt buckles can pass through the magnetic field without causing an alarm. The **Classic** Metal Detector is **compact and lightweight** making this portable unit adoptable to any surroundings. The patented cylinder design is aesthetically suitable for the most discrete applications. This security equipment **does not require any special training** for normal use making this the most "user friendly" walk-through metal detector in the industry. CEIA metal detectors have been selected by the leading security agencies worldwide to protect high ranking government officials. The **Classic** conforms to all International Security Standards and is capable of detecting both magnetic and non-magnetic weapons. When security, operating efficiency and affordable pricing are required the CEIA **Classic** metal detector is the solution. The **Classic** is manufactured using the most advanced electronics technology, conforming to **ISO 9001 Quality Control Standard** procedures.



**Classic/Navy** MODEL IS PARTICULARLY SUITABLE FOR ENVIRONMENTS WITH LIMITED HEADROOM, AND FEATURES AN ELECTRONICS UNIT IN A STAINLESS STEEL IP55 CONTAINER.

## TECHNICAL DATA

### MAIN FEATURES

- Digitally adjustable sensitivity with a wide range of values.
- All functions are controlled by a microprocessor.
- Programming access protected by hardware key.
- Automatic synchronization between two or more metal detectors, at a distance of up to 5 cm, from each other, without using cables
- Professional high integration and high reliability electronics.
- Electronic control unit integrated in the archway.
- No initial or periodic calibration.
- Easy maintenance. Modular control unit for a rapid replacement.
- Colour: light grey RAL 7040.

### INSTALLATION DATA

- Power Supply: 115 VAC (230 VAC available on request) ±15%, 45-65 Hz, 20 VA MAX.
- Operative temperature: from -15°C (5°F) to +70°C (158°F)
- Relative humidity: from 0 to 95% (without condensation).

### CERTIFICATION AND CONFORMITY

- Harmless to wearers of pacemakers, defibrillators or other vital support systems, pregnant women and magnetic storage media (floppy disks, audio cassettes, video cassettes and similar).
- Conforms to the current International Security Standards for Walk-Through Metal Detectors.
- Complies with EC regulations and international standards relating to electrical safety and electromagnetic compatibility (EMC).

### ALARMS

#### VISIBLE SIGNALS

- High intensity display.
- Green and red signals.
- Signal proportional to the mass of the object detected.

#### AUDIBLE SIGNALS

- High acoustic intensity alarm signal.
- Volume and tone of alarm signal can be programmed.
- Duration proportional to the size of the metal mass in transit.

### ACCESSORIES / OPTIONS

- Steel stabilizer plates for portable applications.
- Metal test samples.
- External Main Battery & Supply Unit MBSU, including emergency batteries, that provide about 8 hours of independent operation and an automatic charger.

### UNDER THE ALARM THRESHOLD

- Small metal mass
- Medium metal mass

### OVER THE ALARM THRESHOLD

- Medium metal mass
- Large metal mass

GREEN AND RED METERING SIGNALS PROPORTIONAL TO THE METAL MASS DETECTED

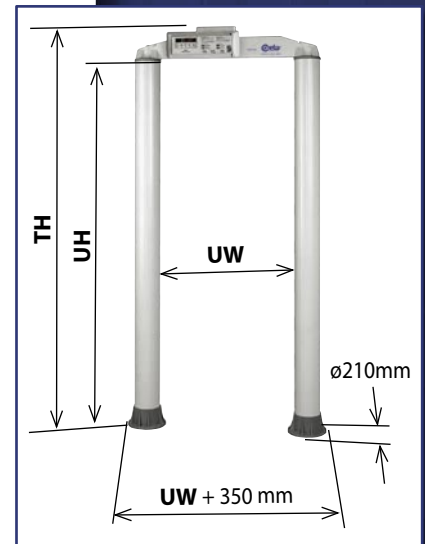

	Classic	Classic/Navy
UW	720 / 820* mm	720 / 820* mm
UH	1965 mm	1835 mm
TH	2152 mm	2000 mm

\* available on request

OVERALL DIMENSIONS



Zona Industriale 54/G, 52040 Vicinaggio - Arezzo (ITALY)  
 Tel.: 0575 4181 Fax: 0575 418298  
 E-mail: infosecurity@ceia-spa.com Web: www.ceia.net